

GEO 205



Dati Tecnici - Technical Data - Caractéristiques Techniques - Technische Daten

| | | | | | |
|------------------------------------------------|----------------------------------------------------|--------------------------------------|-----------------------------------|-----------------------------------|-----------------------------------|
| Carro cingolato Undercarriage | Chariot chenille Fahrwerk | | | | |
| Passo cingolo Wheel base | Enpattement Radstand | 1.080 - 1.380 mm / 3,5 - 4,5 ft | | | |
| Larghezza max. Max width | Largeur max. Gesamtbreite | 750 - 1.150 mm / 2,5 - 3,8 ft | | | |
| Larghezza suole Pad width | Largeur patins Kettenplattenbreite | 230 mm / 9,0 in | | | |
| Pendenza max. Max. climbing ability | Pente max. Steigfähigkeit max. | 36 % | | | |
| Velocità max. Max. speed | Vitesse max. Fahrgeschwindigkeit | 1,5 km/h / 0,93 mph | | | |
| Centrale idraulica Power pack | Groupe hydraulique Hydraulikaggregat | | | | |
| Motore diesel Diesel engine | Moteur diesel Dieselmotor | KUBOTA V1505T | | | |
| Potenza motore Engine power | Puissance moteur Motorleistung | 31 kW (42 HP) / 3.000 rpm | | | |
| Serbatoio olio Oil tank | Réservoir huile Öltank | 130 l / 34,3 gal | | | |
| Serbatoio gasolio Fuel tank | Réservoir diesel Dieseltank | 30 l / 7,9 gal | | | |
| Mast Mast | Mât Lafette | | | | |
| Corsa utile Feed stroke | Course utile Vorschub | 2.430 mm 8,0 ft | 1.030 - 2.430 mm 3,3 - 8,0 ft | 1.300 - 2.800 mm 4,3 - 9,2 ft | 1.500 - 2.500 mm 4,9 - 8,2 ft |
| Lunghezza totale Total length | Longueur totale Gesamtlänge | 3.660 mm 12,0 ft | 2.320 - 3.720 mm 7,6 - 12,2 ft | 2.520 - 4.020 mm 8,2 - 13,1 ft | 2.660 - 3.760 mm 8,7 - 12,3 ft |
| Forza di spinta Feed force | Poussée Vorschubkraft | 2.500 daN / 5,620 lbs | | | |
| Forza di tiro Retract force | Traction Rückzugskraft | 2.500 daN / 5,620 lbs | | | |
| Testa di rotazione Rotary head | Tête de rotation Drehkopf | R 300 | | R 400 | |
| Marce Gears | Vitesses Gänge | 2 | | 4 | |
| Coppia max. Max torque | Couple max. Drehmoment max. | 320 daNm / 2,360 lb*ft | | 380 daNm / 2,802 lb*ft | |
| Giri max. Max speed | Vitesse max. Drehzahl max. | 160 rpm | | 500 rpm | |
| Passaggio testa Head passage | Passege de la tête Drehkopfdurchgang | 50 mm / 1,9 in | | 50 mm / 1,9 in | |
| Morse Clamps | Mors Klemm- und Brechvorrichtung | | | | |
| Diametro min. / max di presa Clamping range | Tige/diamètre min. / max Durchmesser min. / max | 45 - 170 mm / 1,5 - 6,6 in | | 45 - 220 mm / 1,5 - 8,6 in | |
| Forza di chiusura Clamping force | Force de serrage Klemmkraft | 130 KN / 29,225 lbs | | | |
| Coppia svitaggio Breaking torque | Couple de deserrage Brechmoment | 1.000 daNm / 7,37 lb*ft | | | |
| Peso Weight | Poids Gewicht | 2.400 - 2.700 kg / 5,000 - 6,000 lbs | | | |

Opzioni ed Accessori - Options and Accessories - Options et Accessoires - Optionen und Zubehör

Gruppo morsa svitatore
 Rod holder and combined breaker
 Groupe mors/blocage et dévissage
 Bohrstangenhalter mit Brech- und Lösevorrichtung

Morsa semplice / Single clamp
 Simple mors / Einfachklemme

Martinetto svitatore con chiave
 Hydraulic breakout cylinder
 Piston dévissageur avec clef
 Brechzylinder mit Schlüssel

Centratore guida aste/eliche
 Rod/auger guiding device
 Guide tige/tarière
 Anbohrführung für Bohrgestänge und Schneken

Argano idraulico / Hydraulic winch
 Treuil hydraulique / Hydraulische Seilwinde

Martello idraulico / Hydraulic drifter
 Tête à rotopercussion / Hydraulikhammer

Pompa schiumogeno / Foam pump
 Pompe à mousse / Schaumpumpe

Pompa acqua / Water pump
 Pompe à eau / Wasserpumpe

Lubrificatore di linea / D.T.H. lubricator
 Graisseur de ligne / Linienöler

Fari di lavoro / Work lights
 Phares de travail / Arbeitsscheinwerfer

Martinetti estrattori / Casing extractor cylinders
 Extracteur pour tubes / Schutzrohr-Ausbrechzylinder

Penetrometro per SPT / SPT Penetrometer
 Pénétrömètre SPT / SPT-Sonde

Argano Wire-line / Wire-line winch
 Treuil Wire-line / Seilkernwinde

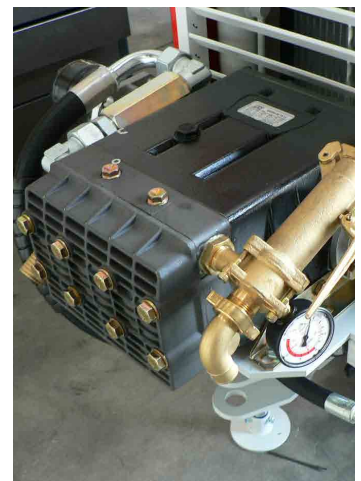
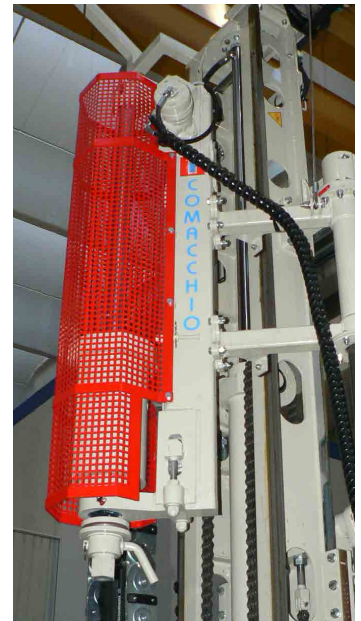

GEO 205

Dimensioni di ingombro (mm) - Overall dimensions (mm) - Dimensions (mm) - Aussenabmessungen (mm)

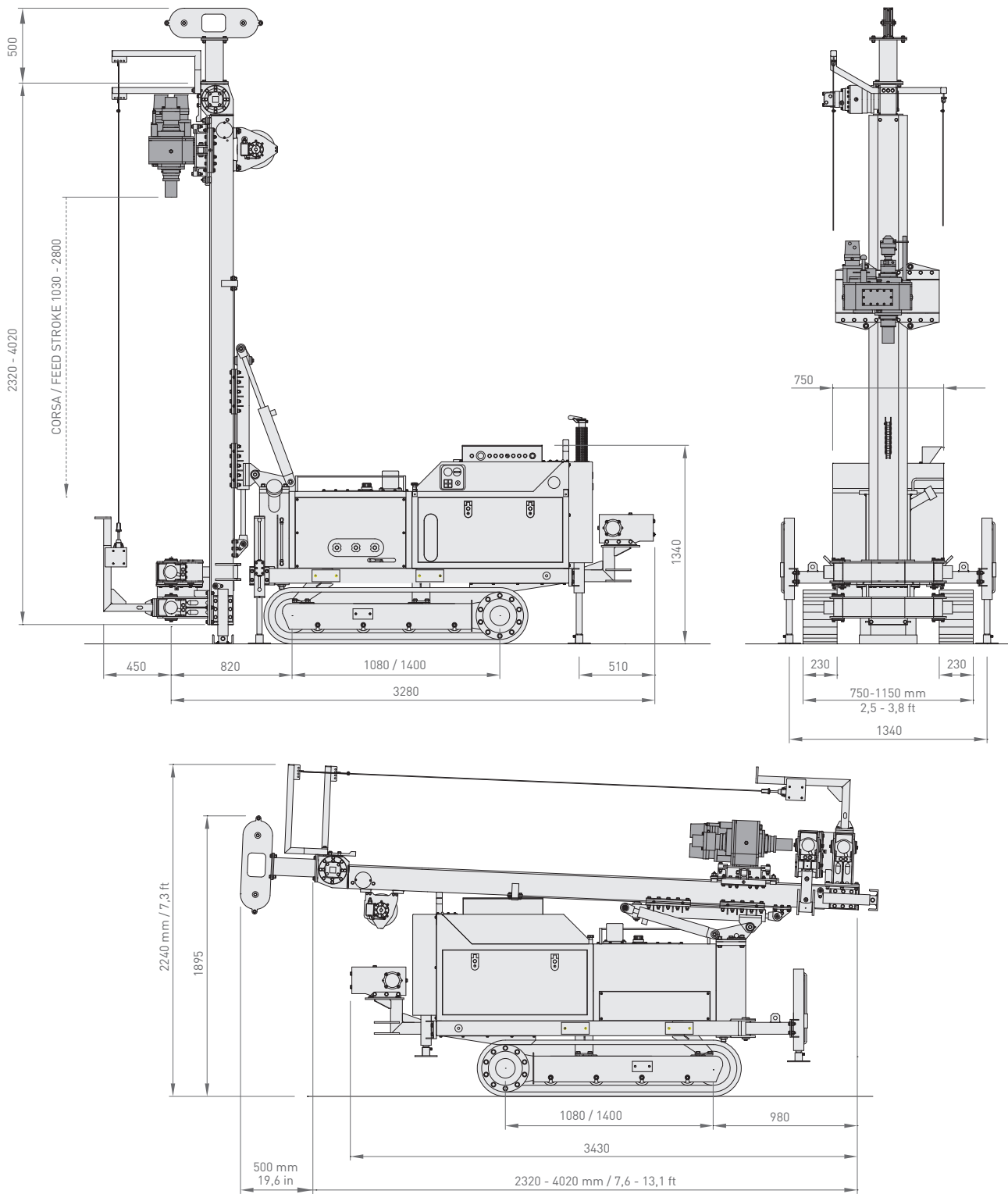

Comacchio s.r.l.

Via Callalta, 24/B - 31039 Riese Pio X (TV) (Italy)

Tel +39 0423 7585 - Fax + 39 0423 755592

sales@comacchio-industries.it - www.comacchio-industries.it